



# CONDAIR PUREFLO

Water filter for humidifiers  
High efficiency, all-in-one system



Humidification and Evaporative Cooling

 **conda**ir  
The new name for JS Humidifiers

# RO water for improved humidification

Reverse osmosis (RO) is an effective and economic way of removing minerals from water. The PureFlo RO has been developed specifically to provide operational, energy and maintenance benefits to Condair humidifiers.

By removing the minerals from a humidifier's supply water, the limescale that builds up in the system is virtually eliminated. This results in a much lower level of required maintenance in all types of humidifier and reduced energy consumption in steam humidifiers. These cost savings can lead to a payback on the initial purchase of the PureFlo RO unit in around one year.

Steam humidifiers that run on mains water need to drain their boiling chambers occasionally to maintain a low mineral content and reduce limescale build-up. By using RO supply water, the steam humidifier's boiling chamber does not require this regular drain. Therefore it uses less energy to maintain the water's temperature.

As the water temperature is consistent, the steam output is also consistent thus improving humidity control. By using resistive steam humidifiers fed by RO water  $\pm 1\%RH$  control can be achieved.

Other benefits of using RO water with humidifiers include increasing the life of the evaporative pads in evaporative humidifiers and preventing dust carry-over in spray humidifiers.

## Benefits

- Virtually eliminates scale build-up in humidifiers
- Reduces maintenance time and cost
- Reduces energy consumption
- Enables precise humidity control
- Extends humidifier life

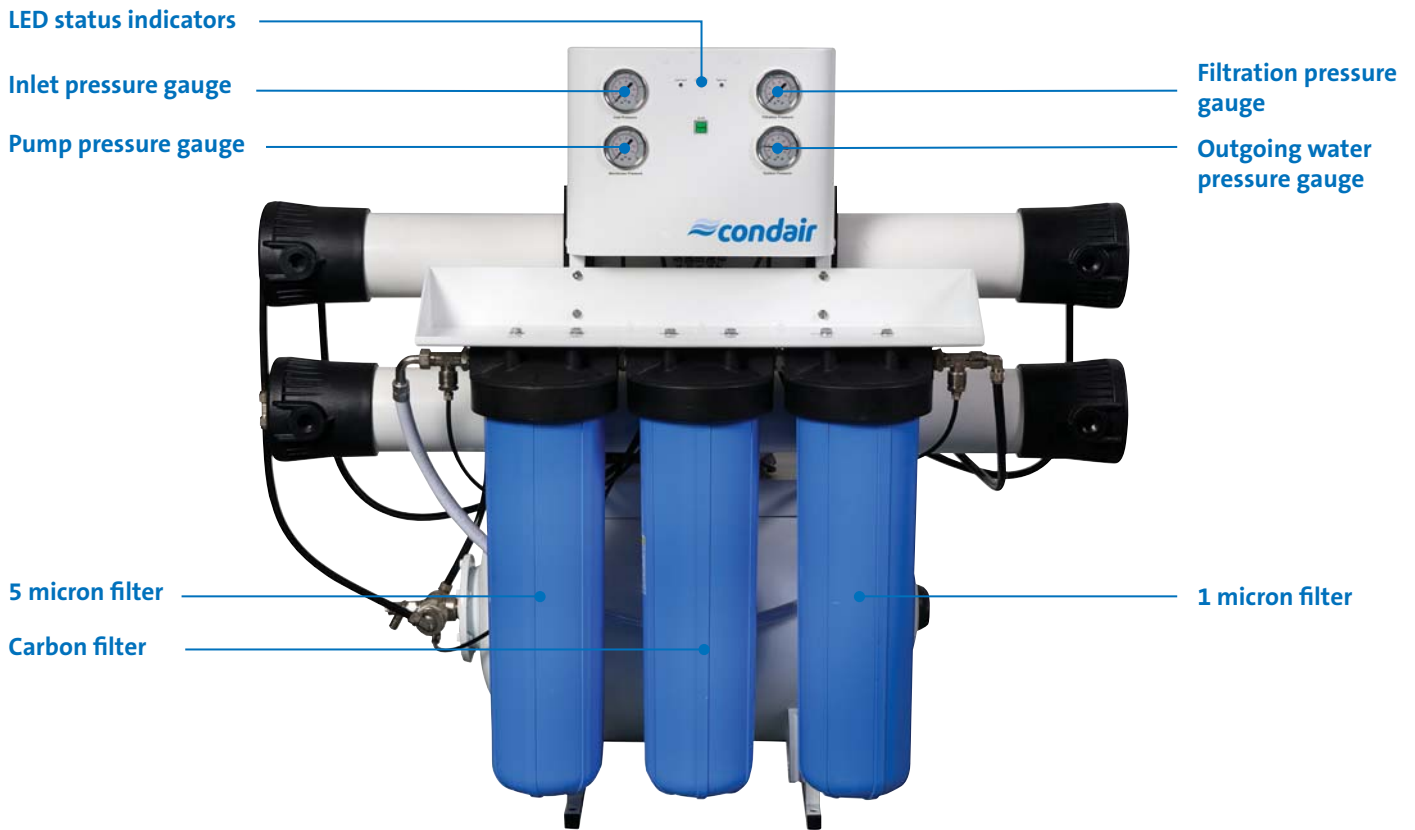

The PureFlo RO filter is an all-in-one water treatment system, requiring no associated pumps or tanks to operate.

Three models supply up to 100, 250 or 500 litres of RO water per hour at a supply pressure of up to 3bar.

The system has a typical total dissolved solids rejection rate of up to 95% and a

very high recovery rate, delivering up to 50% of the supply water as RO water. The unit comes complete with a 3-stage pre-filtration assembly that removes chlorine and any non-dissolved particles down to one micron.

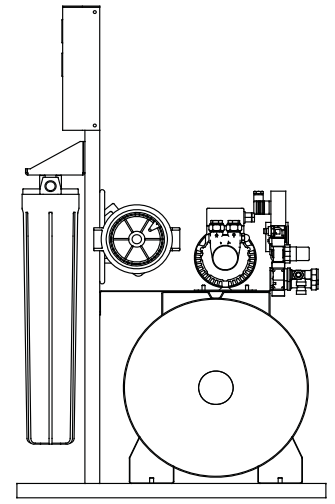
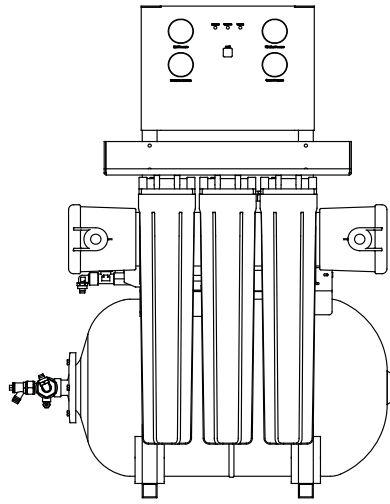

## Specifications

Performance	RO-100	RO-250	RO-500
Product water flow output @10°C(L/h)	100	250	500
Product water pressure output (bar)	1-3	1-3	1-3
Rejection (typical) TDS (%)	95	95	95
Recovery (%)	50	50	50
Integral water storage (litres)	23	23	23

Electrical requirements	RO-100	RO-250	RO-500
Voltage (V)	230	230	230
Power (kW)	0.35	0.35	0.35
Fuse rating (Amps)	5	5	5

Dimensions and weights	RO-100	RO-250	RO-500
Dry weight (kg)	46	64	73
Operating weight (kg)	73	92	99
Height (mm)	1065	1065	1065
Width (mm)	785	1129	1129
Depth (mm)	610	670	670